

FI SERIES

Vehicle application

S30

S30 ENT C

This publication describes the characteristics, data and correct methods for repair operations on each component of the vehicle.

If the instructions provided are followed and the specified equipment is used, correct repair operations in the programmed time will be ensured, safeguarding against possible accidents.

Before starting to perform whatever type of repair, ensure that all accident prevention equipment is available and efficient.

All protections specified by safety regulations, i.e.: goggles, helmet, gloves, boot, etc. must be checked and worn.

All machining, lifting and conveying equipment should be inspected before use.

The data contained in this publication was correct at the time of going to press but due to possible modifications made by the Manufacturer for reasons of a technical or commercial nature or for adaptation to the legal requirements of the different countries, some changes may have occurred.

No part of this publication, including the pictures, may be reproduced in any form or by any means.

Publication edited by
Iveco Motors
Iveco SpA
PowerTrain
Mkt. Advertising & Promotion
Viale dell'Industria, 15/17
20010 Pregnana Milanese
Milano (Italy)
Print **P1D32S001GB/W** - 1st Ed. 02.2006
S30 ENT C Series

Produced by:











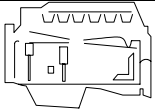
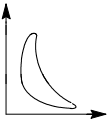
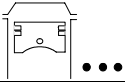
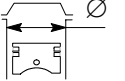
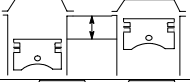

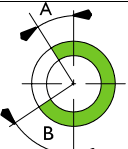

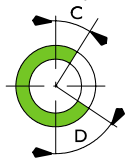

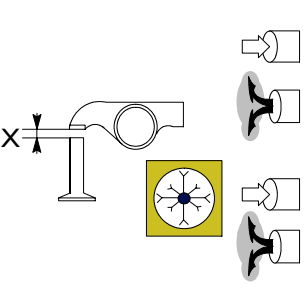
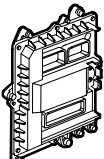
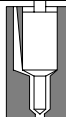
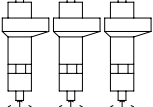
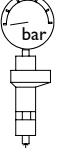

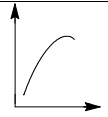

B.U. TECHNICAL PUBLISHING
Iveco Technical Publications
Lungo Stura Lazio, 15/19
10156 Turin - Italy

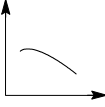
CORRESPONDENCE BETWEEN TECHNICAL CODE AND COMMERCIAL CODE

Technical Code	Commercial Code
FICE048IB*...	S30 ENT C
FICE048IA*...	S30 ENT C

SPECIFICATIONS

	Type	S30 ENT C SERIES	
	Cycle	Four-stroke diesel engine	
	Power	Supercharged with intercooler	
	Injection	Direct	
	Number of cylinders	4 in-line	
	Bore	mm	95.8
	Stroke	mm	104
	Total displacement	cm ³	2998
TIMING			
	 start before T.D.C.	A	24°
	end after B.D.C.	B	26°
	 start before B.D.C.	D	70°
	end after T.D.C.	C	24°
	Checking timing	mm	-
	X	mm	-
	Checking operation	mm	-
	X	mm	-
FUEL FEED			
	Injection Type:	Bosch	high pressure common rail EDC16
	Nozzle type	Injectors BOSCH	
	Injection sequence	1 - 3 - 4 - 2	
	Injection pressure	bar	1600



S30 ENT C Series engines			TECHNICAL CODE	
	Type		FICE0481A*....	FICE0481B*....
	Maximum power	kW (HP)	100 (136)	122 (166)
		rpm	3500	3500
	Torque at 1000 rpm	Nm	240	250
	Maximum torque	kW (HP)	340 (34.5)	380 (38.7)
		rpm	1400 ÷ 2800	1250 ÷ 3070
	Slow running of engine with no load	rpm	800 ± 25	
	Fast idling speed of engine with no load	rpm	4200 ± 50	
	Pressure at T.D.C.	*bar	20 ÷ 26	
	Minimum permissible pressure at T.D.C.	*bar	16	
	Bore x stroke	mm	95.5 x 104	
	Displacement	cm ³	2998	
	TURBOCHARGING		With intercooler	
	Turbocharger type		MITSUBISHI TD 04 - HL - 13T-6 con Waste-Gate	GARRETT GT 2260 V variable geometry
	Turbocharger shaft radial play		0.396 ÷ 0.602	0.086 ÷ 0.117
	Turbocharger shaft end float		0.034 ÷ 0.106	0.030 ÷ 0.083
	Minimum stroke of pressure relief valve opening	mm	1	-
	Maximum stroke of pressure relief valve opening	mm	5	-
	Pressure corresponding to minimum stroke:	bar	1.21 ± 0.0026	-
	Pressure corresponding to maximum stroke:	bar	1.45 ± 0.0039	-
	LUBRICATION		forced by gear pump, pressure relief valve, oil filter with double filtering	
	 Oil pressure with engine hot (100°C ± 5°C):			
	at idling speed	bar	1.0	
	at top speed	bar	5.0	
	COOLING		by centrifugal pump, thermostat for adjustment, coolant temperature, fan with electromagnetic coupling, radiator, heat exchanger	
	Water pump control:		by belt	
	Thermostat:		N. I.	
	start of opening:		79 °C ± 2 °C	
	max opening:		94 °C ± 2 °C	

(*) The pressure is measured by setting the engine turning with the aid of just the starter motor, with an oil temperature of 40 – 50°C.

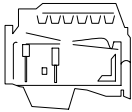

Data, features and performances are valid only if the setter fully complies with all the installation prescriptions provided by Iveco Motors.

Furthermore, the users assembled by the setter shall always be in conformance to couple, power and number of turns based on which the engine has been designed.







		TECHNICAL CODE	
		FICE0481A*....	FICE0481B*....
	Type		
	FLUIDS		
	Quantity of oil for first filling	liters	7.6
	Urania Daily	kg	5.81
	Urania LD 5		
	Periodical replacement capacity	litres	7.6
		kg	6.79



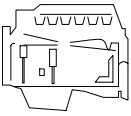
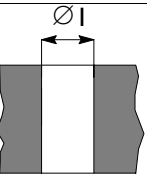
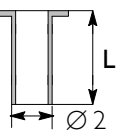

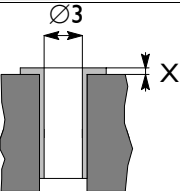
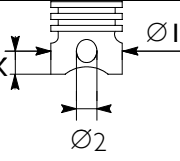

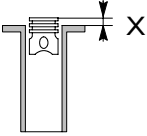
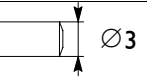



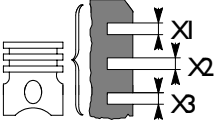
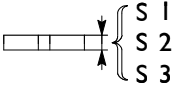

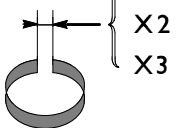
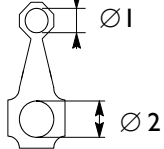
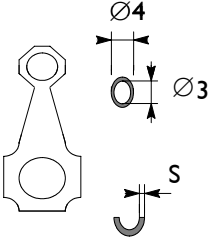
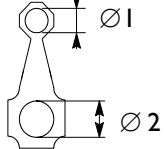
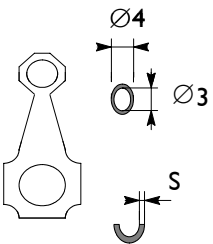
Data, features and performances are valid only if the setter fully complies with all the installation prescriptions provided by Iveco Motors.



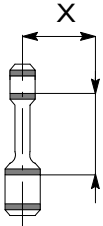
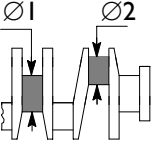
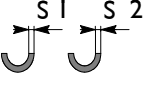
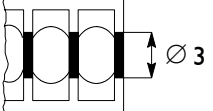



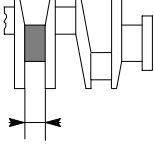
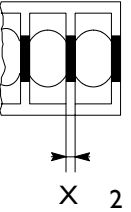
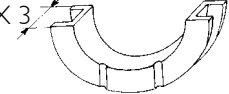



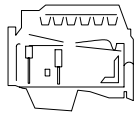
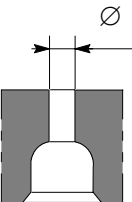
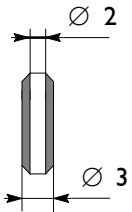



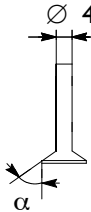



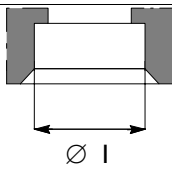

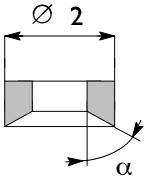
Furthermore, the users assembled by the setter shall always be in conformance to couple, power and number of turns based on which the engine has been designed.

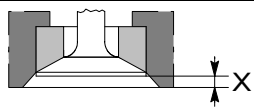





ASSEMBLY DATA – CLEARANCES

 Type	S30 ENT C SERIES	
CYLINDER ASSEMBLY AND CRANK MEMBERS		
	Cylinder liners: $\varnothing 1$	95.802 ± 95.822
	Cylinder liners: outside diameter \varnothing length L	- - -
	Cylinder liners – crankcase seats (interference)	-
	Outside diameter $\varnothing 2$	-
	Cylinder liners: (protrusion from bottom of crankcase) inside diameter $\varnothing 3$	- -
	Pistons: supplied as spares type measurement X outside diameter $\varnothing 1$ seat for pin $\varnothing 2$	MAHLE 58 95.591 ± 95.605 36.003 ± 36.009
	Piston – cylinder liners	0.197 ± 0.231
	Piston diameter $\varnothing 1$	0.4
	Piston protrusion from crankcase X	0.3 ± 0.6
	Piston gudgeon pin $\varnothing 3$	35.990 ± 35.996
	Piston gudgeon pin – pin seat	0.07 ± 0.019

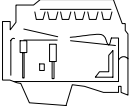
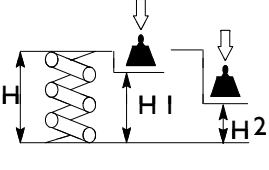
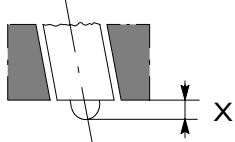
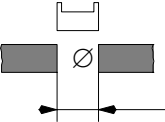
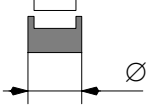
 Type	S30 ENT C SERIES	
CYLINDER ASSEMBLY AND CRANK MEMBERS		
		mm
 Type of piston X1* Piston ring slots X2 X3 * measured on \varnothing of 92.5 mm		- 2.197 2.200 \pm 2.230 2.040 \pm 2.060 2.050 \pm 2.070 2.520 \pm 2.540 2.540 \pm 2.560
 Piston rings: S1* S2 S3 * measured at 1.5 mm from the external \varnothing .		2.068 \pm 2.097 1.970 \pm 1.990 2.470 \pm 2.490
 Piston rings – slots 1 2 3		0.103 \pm 0.162 0.060 \pm 0.100 0.050 \pm 0.090
 Piston rings		0.4
 Piston ring end opening in cylinder liner: X1 X2 X3 X1 X2 X3		0.20 \pm 0.35 0.60 \pm 0.80 0.25 \pm 0.60
 Small end bushing seat \varnothing 1 Connecting rod bearing seat* \varnothing 2 * connecting rod supplied as spare part		39.460 \pm 39.490 67.833 \pm 67.848
 Small end bushing diameter outside \varnothing 4 inside \varnothing 3 Big end bearing shells supplied as spare part S		39.570 \pm 39.595 36.010 \pm 36.020 - 1,883 \pm 1,892 1,885 \pm 1,891
 Small end bushing – seat (interference)		0.08 \pm 0.135
 Piston gudgeon pin – bushing		0.014 \pm 0.030
 Big end bearing shells		0.254 - 0.508

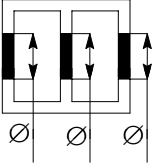
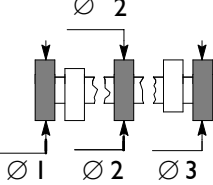
 Type	S30 ENT C SERIES	
CYLINDER ASSEMBLY AND CRANK MEMBERS		
 Measurement X Maximum error on alignment of connecting rod axes =	X	mm 125 0.09
  Main journals No. 1-2-3-4 No. 5 Crankpins Main bearing shells Big end bearing shells * supplied as spare parts	Ø 1 Ø 2 S1* S2*	76.182 ÷ 76.208 83.182 ÷ 83.208 64.015 ÷ 64.038 2.165 ÷ 2.174 1.883 ÷ 1.892 1.885 ÷ 1.891
 Main bearing housings No. 1-2-3-4 No. 5	Ø 3	80.588 ÷ 80.614 87.588 ÷ 87.614
 Bearing shells - main journals		0.032 ÷ 0.102
 Bearing shells - crankpins		0.035 ÷ 0.083
 Main bearing shells Big end bearing shells		0.254 ÷ 0.508 0.254 ÷ 0.508
 Main journal for shoulder	X 1	32.500 ÷ 32.550
 Main bearing housing for shoulder	X 2	27.240 ÷ 27.290
 Half thrust washers	X 3	32.310 ÷ 32.460
 Crankshaft shoulder		0.040 ÷ 0.240

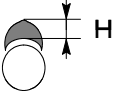
 Type		S30 ENT C SERIES	
CYLINDER HEAD – TIMING SYSTEM		mm	
 Guide valve seats on cylinder head	Ø1	9.980 ÷ 10.000	
 Valve guides	Ø 2  Ø 3	6.023 ÷ 6.038 10.028 ÷ 10.039	
 Valve guides and seats on head (interference)		0.028 ÷ 0.059	
  > Valve guides		0.05 - 0.10 - 0.25	
 Valves:	 Ø 4 α  Ø 4 α	5.985 ÷ 6.000 60° ±7.5' 5.975 ÷ 5.990 60° ±7.5'	
 Valve stem and relevant guide		0.023 ÷ 0.053	
 Seat on head for valve seat:	 Ø 1  Ø 1	34.490 ÷ 34.415 34.490 ÷ 34.515	
 Outside diameter of valve seats; angle of valve seats on cylinder head:	 Ø 2 α  Ø 2 α	34.590 ÷ 34.610 59.5° ±5' 34.590 ÷ 34.610 59.5° ±5'	
 Recessing	X  X 	0.375 ÷ 0.525 0.375 ÷ 0.525	
 Between valve seat and head	 	0.075 - 0.12 0.075 - 0.12	
  > Valve seats		-	

 Type	S30 ENT C SERIES	
CYLINDER HEAD – TIMING SYSTEM		
 Valve spring height: free spring H under a load of: N243 ± 12 H1 N533 ± 24 H2	mm	
 Injector protrusion X		2.77 ± 3.23
 Seats for tappets on cylinder head normal Ø		12.016 ± 12.034
 Normal diameter tappets		11.988 ± 12.000
 Between tappets and seats		0.016 ± 0.046
 Camshaft pin seats in cylinder overhead 1 ⇒ 7	Ø 1 Ø 2 Ø 3	48.988 ± 49.012 46.988 ± 47.012 35.988 ± 36.012
 Camshaft supporting pins:	Ø 1 Ø 2 Ø 3	48.925 ± 48.950 46.925 ± 46.950 35.925 ± 35.950
 Supporting pins and seats		0.032 ± 0.087
 Useful cam height	 H  H	3.622 4.328

TOOLS

TOOL NO.

DESCRIPTION

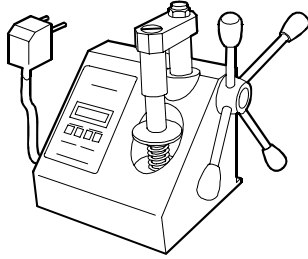
99305047

Appliance to check spring loads

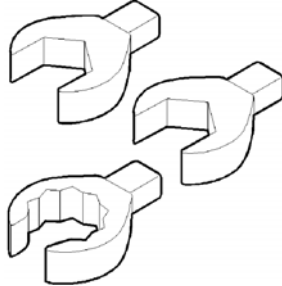
99317915

Set of six box-type wrenches (14-17-19 mm)

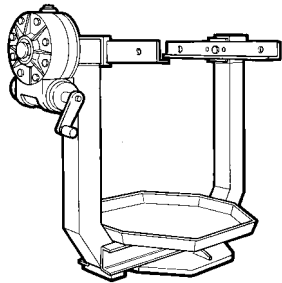
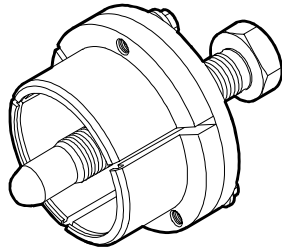
99322205Rotary telescopic stand for overhauling assemblies
(capacity 700 daN, torque 120 daN/m)**99340059**

Extractor for camshaft pulley

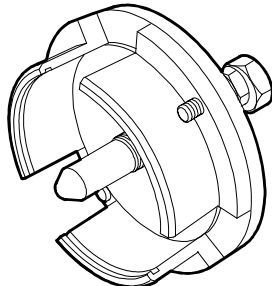
99340060

High-pressure pump toothed pulley extractor

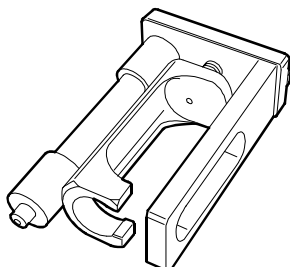
99342153

Tool to remove crankshaft front gasket

TOOLS

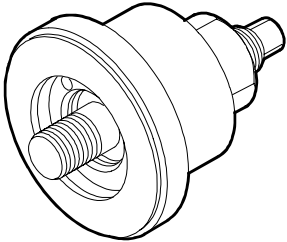
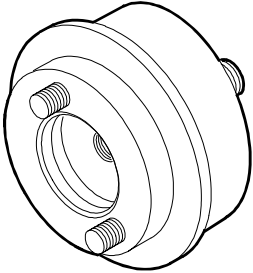
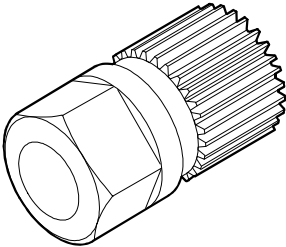
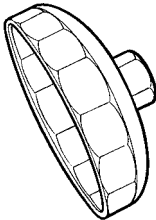
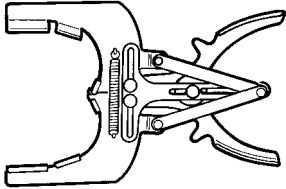
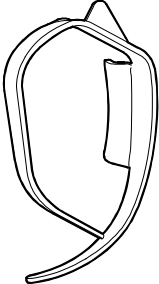
TOOL NO.	DESCRIPTION
99346258	Keying device for mounting crankshaft front gasket
	
99346259	Keying device for mounting crankshaft rear gasket
	
99358026	Wrench for alternator pulley (free wheel) removal/refitting
	
99360076	Tool to remove cartridge filters
	
99360183	Pliers for mounting rings on engine pistons
	
99360186	Guide for flexible belt
	

TOOLS

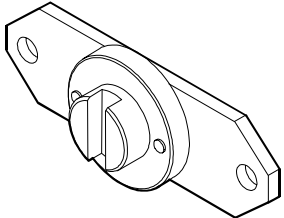
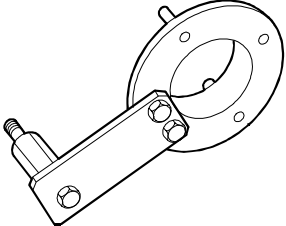
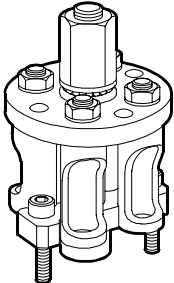
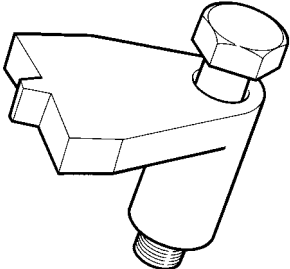
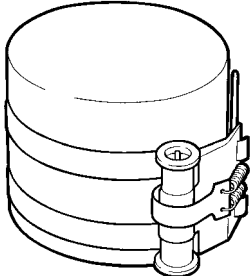
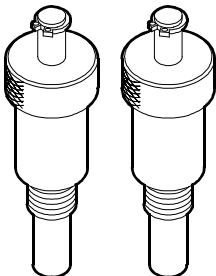
TOOL NO.	DESCRIPTION
99360187	Retaining tool for hydraulic power steering control shaft
	
99360190	Damper pulley retaining tool
	
99360260	Tool for removing and refitting engine valves
	
99360306	Tool to retain engine flywheel
	
99360605	Band to insert standard and oversized pistons into the cylinders
	
99360614	Tool (2) for camshaft timing
	

TOOLS

TOOL NO.

DESCRIPTION

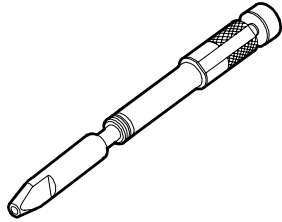
99360615

Tool for crankshaft timing

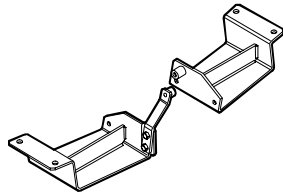
99361041

Brackets securing engine to rotary stand 99322205

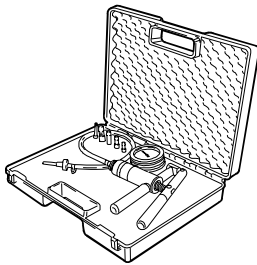
99367121

Manual pump to measure pressure and vacuum

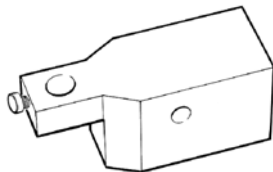
99370415

Dial-gauge base for various measurements (to be used with 99395603)

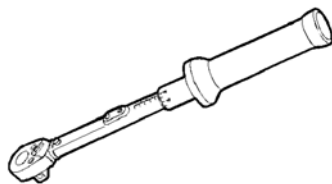
99389817

Dynamometric wrench (60 ÷ 320 Nm) with 3/4" coupling

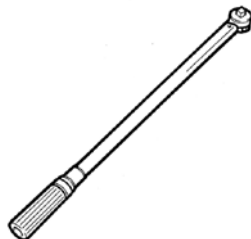
99389818

Dynamometric wrench (150-800 Nm) with 3/4" square coupling

TOOLS

TOOL NO.

DESCRIPTION

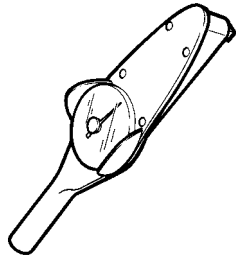
99389819

Torque wrench (0-10 Nm) with square 1/4" connection

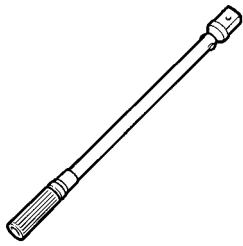
99389829

9x12 coupling torque wrench (5-60 Nm)

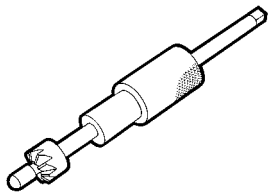
99394038

Milling cutter to regrind injector seat

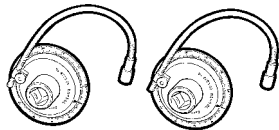
99395216

Pair of meters for angular tightening with square 1/2" and 3/4" connection

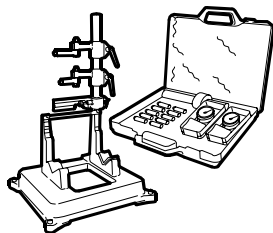
99395363

Complete square to check for connecting rod distortion

99395603

Dial gauge (0-5 mm)

TOOLS

TOOL NO.

DESCRIPTION

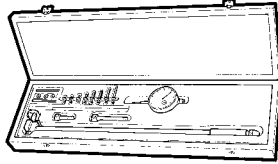
99395687

Bore meter (50 – 178 mm)

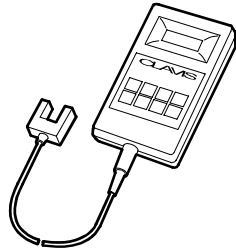
99395849

Belt tension control device (frequency from 10,0 bis 600 Hz)

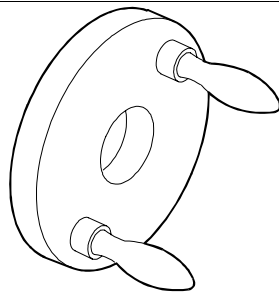
99396039

Centring ring for timing gear cover

EXPERIMENTAL TOOLS

This section shows the working drawings for the experimental tools (S.P.) used in overhauling the engine described in this section, which may be made by the repair shops.

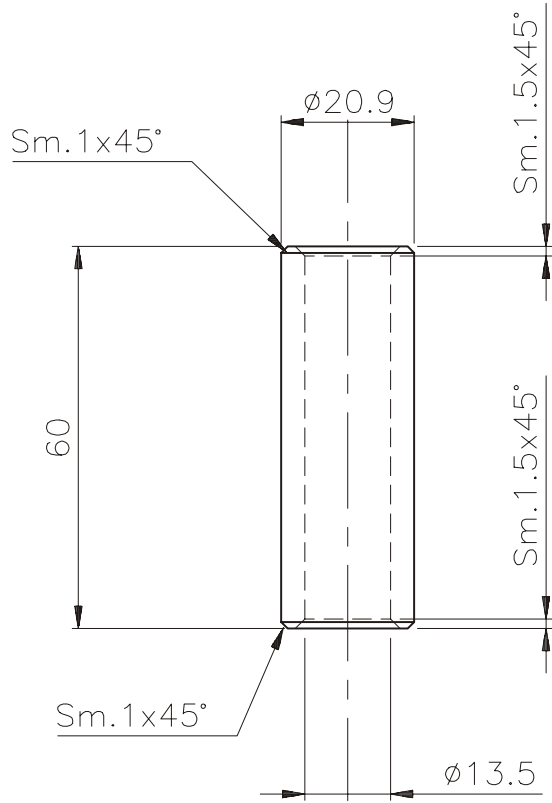

Modification:

For the permissible errors on the dimensions without tolerance and for other general specifications, see **IVECO** STD 10-2311

MAT. Pom / Nylon		COVER. /	DRAWN UTS (B)	N°DRAWING SP. 2264		
All proprietary rights reserved by IVECO . This drawing shall not be reproduced or in any way utilised, for the manufacture or the component or unit herein illustrated and must not be released to other parties, without written consent. Any infringement will be legally pursued.	ISO \leq IT8	Perni di centraggio sovratesta	APPROVED	EXPER. 2264	SIZE A4	
	$\alpha \leq 30'$	e per piantaggio guarnizione	DATE 19/06/2001	SHEET		
	Ra \leq 0.4	guida valvole	SUPERSEDES			
	C/	MOTORI FIA - FIC	SCALE 1:1			
	I.S. 18-0011		Q.TY 2			

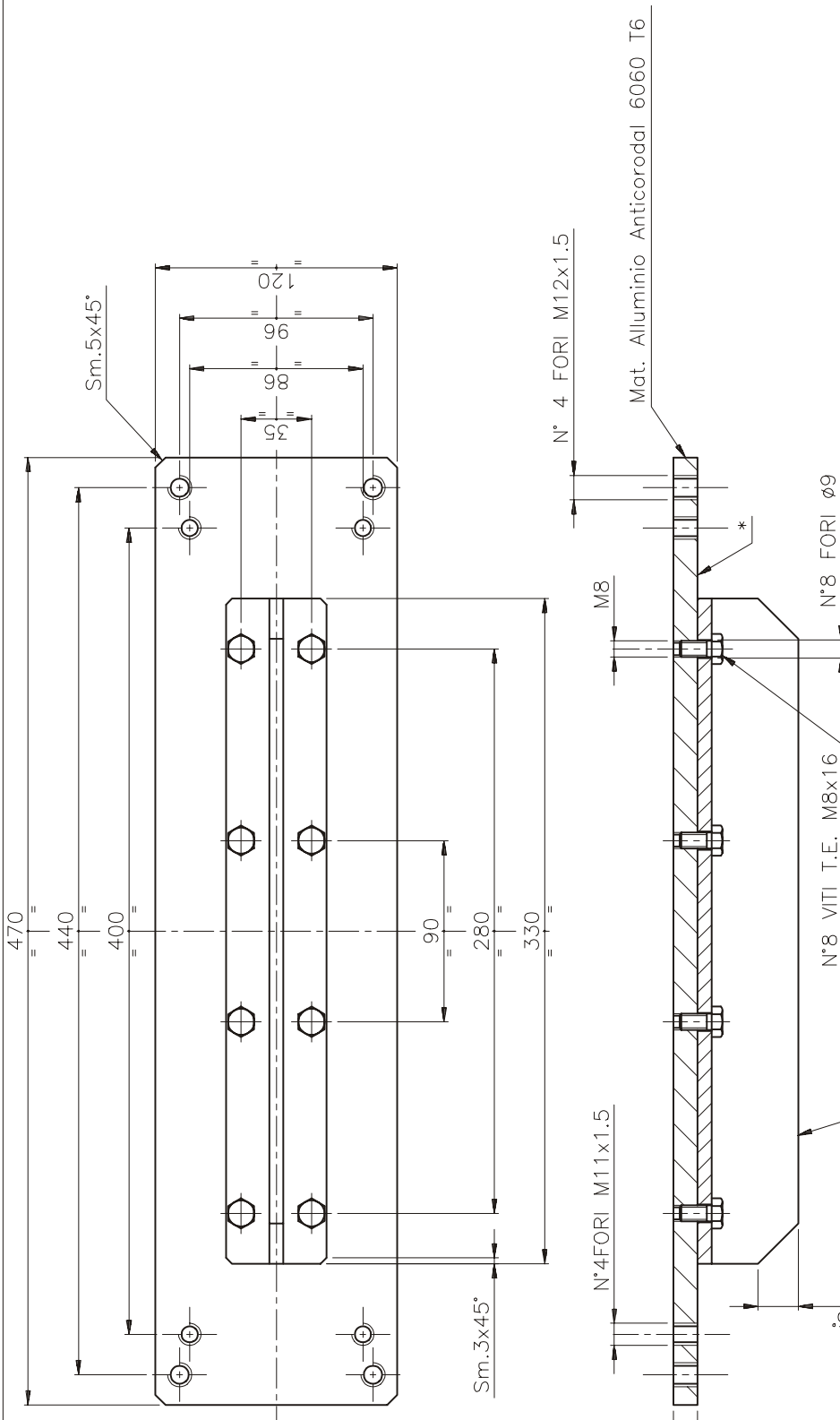

For the permissible errors on the dimensions without tolerance and for other general specifications, see **IVECO** STD 10-2311

MAT. Vedi dis. ISO M 8 M 8 R 4 0.4 +	COVER Vedi dis. Supporto per sostegno testa cilindri	DRAWN UTS (B) APPROVED	N°DRAWING SP. 2271
		DATE 22/11/2001	EXPER. 2271 SIZE A3
SUPPERSEDES		SCALE 1:2	SHEET
Q.TY 1		IVECO	

N° 8 VITI T.E. M8x16
 Mat. CL. 8.8
 N° 8 FORI Ø9
 N° 4 FORI M11x1.5
 N° 4 FORI M12x1.5
 Sm. 20x45
 Mat. Alluminio Anticorodal 6060 T6
 Sm. 5x45*
 Sm. 3x45*

0 / (3 /) Sm. 0.5x45*

All proprietary rights reserved by **IVECO**
 This drawing shall not be reproduced or in any way
 utilized, for the manufacture or the component or unit
 herein illustrated and must not be released to other
 parties, without written consent.
 Any infringement will be legally pursued.

Modification:

VARIA DA ART. COMMERCIALE USAG cod.235EL 1/4" - Ch.8
SOLO PER QUANTO INDICATO

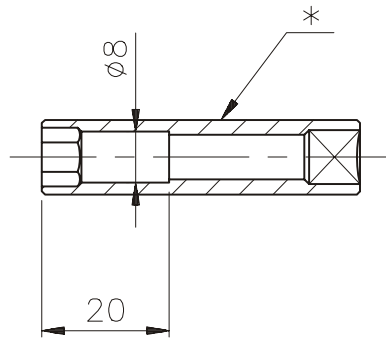

6
Sm. 0.5x45°

Modification:

For the permissible errors on the dimensions without tolerance and for other general specifications, see **IVECO** STD 10-2311

MAT. /		COVER. /	DRAWN UTS (B)	N°DRAWING SP. 2275		
All proprietary rights reserved by IVECO . This drawing shall not be reproduced or in any way utilised, for the manufacture or the component or unit herein illustrated and must not be released to other parties, without written consent. Any infringement will be legally pursued.	ISO \leq IT8 $\alpha \leq 30'$ Ra \leq 0.4	Bussola (8 mm) per montaggio/ smontaggio candele	APPROVED	EXPER. 2275	SIZE A4	
			DATE 25/07/2001	SHEET		
	C/		SUPERSEDES			
	I.S. 18-0011		SCALE 1:1	IVECO		
		MOTORI FIA - FIC	Q.TY 1			

PARTIC. DENTE - Scala 10:1

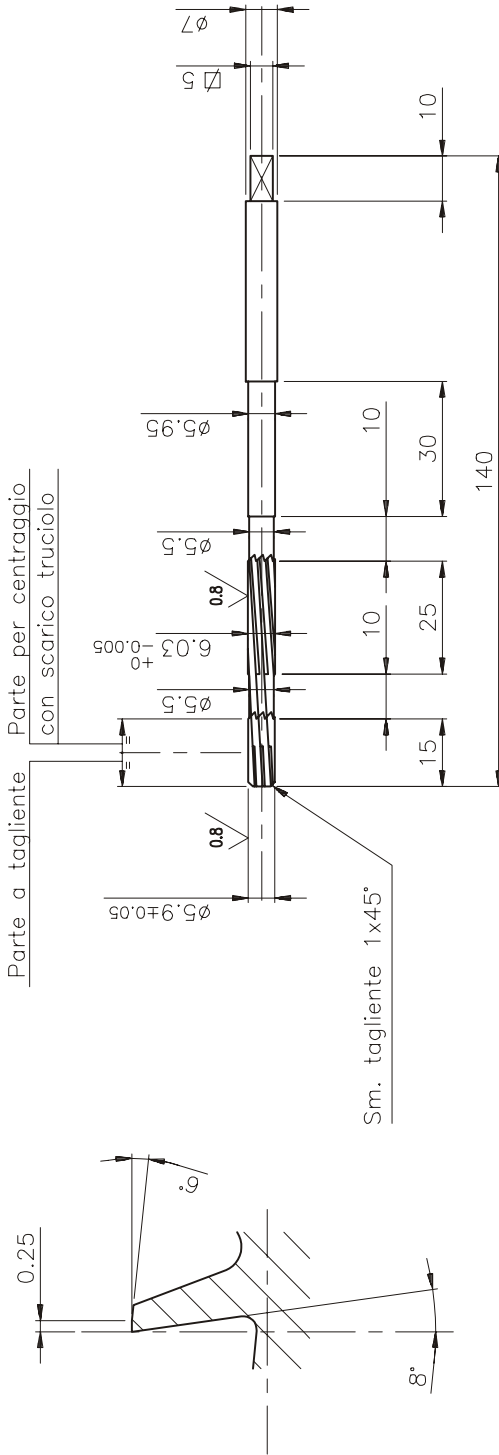

N° 6 DENTI - ELICA SINISTRA - INCLINAZIONE 6°

Modification:

For the permissible errors on the dimensions without tolerance and for other general specifications, see **ISO 10-2311**

MATERIAL: UNI U100WC HRC 62-64		COVER: /		DRAWING: UTS (B)	N° DRAWING: SP. 2310
ISO 428		ISO 428		APPROVED	EXPER. SIZE: A3
+		+		DATE: 10/12/2001	SHEET
1.5.18-0011		1.5.18-0011		SUPERSEDES	
b		b		SCALE: 1:1	
MOTORI FIA - FIC		MOTORI FIA - FIC		Q.TY: 1	
All proprietary rights reserved by IVECO		All proprietary rights reserved by IVECO			
This drawing shall not be reproduced or in any way utilized, for the manufacture or the component or other parts, without written consent.		This drawing shall not be reproduced or in any way utilized, for the manufacture or the component or other parts, without written consent.			
Any infringement will be legally pursued.		Any infringement will be legally pursued.			

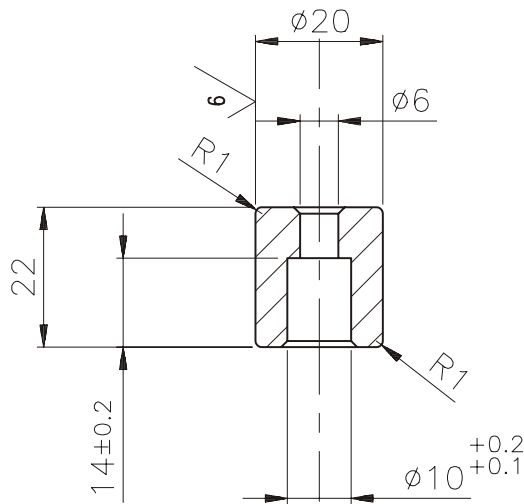

Modification:

For the permissible errors on the dimensions without tolerance and for other general specifications, see **IVECO** STD 10-2311

MAT. 39NiCrMo3 Bon.		COVER. Fosfat.	DRAWN UTS (B)	N°DRAWING SP. 2311		
All proprietary rights reserved by IVECO . This drawing shall not be reproduced or in any way utilised, for the manufacture or the component or unit herein illustrated and must not be released to other parties, without written consent. Any infringement will be legally pursued.	ISO ≤ IT8 α ≤ 30' Ra ≤ 0.4	Battitoio per piantaggio	APPROVED	EXPER. 2311	SIZE A4	
		guida valvole	DATE 10/12/2001	SHEET		
	C/	(usare con sp. 2312)	SUPERSEDES			
	I.S. 19-0011	MOTORI FIA - FIC	SCALE 1:1	IVECO		
			Q.TY 1			

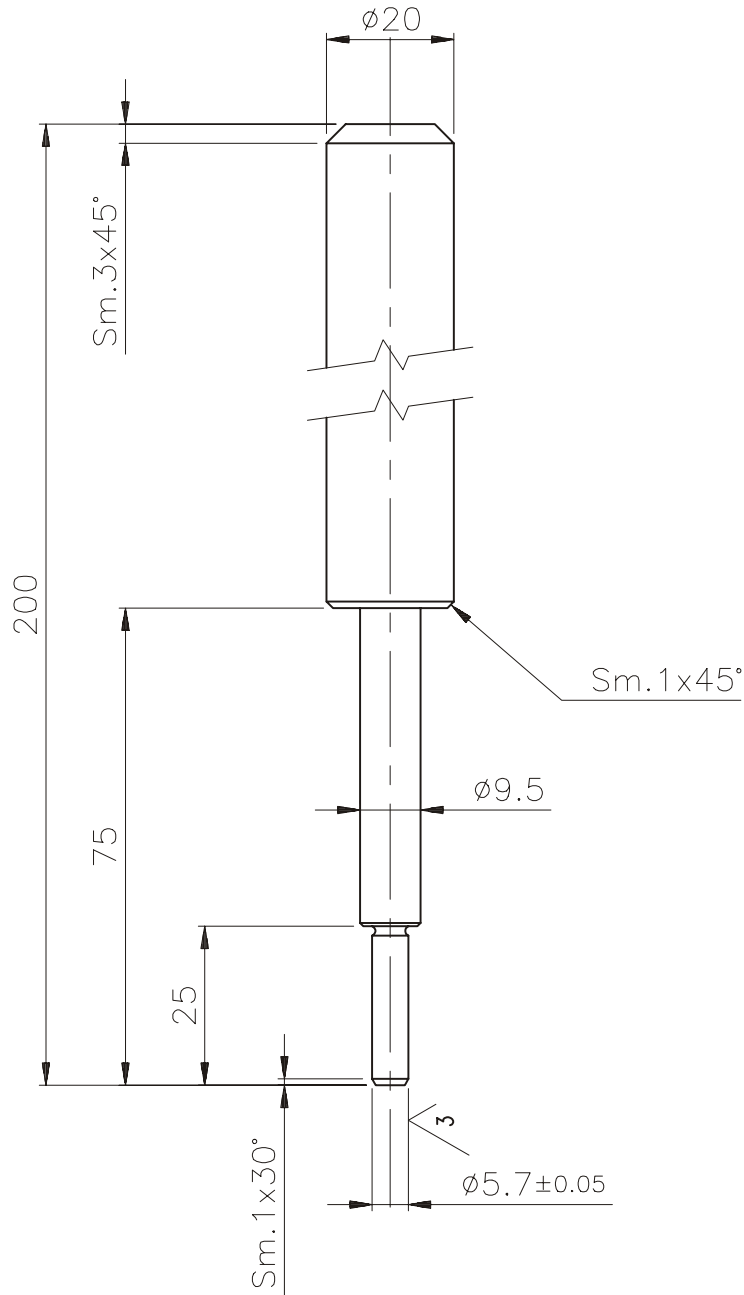

Modification: _____

For the permissible errors on the dimensions without tolerance and for other general specifications, see **IVECO** STD 10-2311

MAT. 39NiCrMo3 Bon.		COVER. Fosfat.	DRAWN UTS (B)	N°DRAWING SP. 2312	
All proprietary rights reserved by IVECO This drawing shall not be reproduced or in any way utilised, for the manufacture or the component or unit herein illustrated and must not be released to other parties, without written consent. Any infringement will be legally pursued. C/ I.S. 18-0011	ISO ≤ IT8 4 ≤ 30° Ra ≤ 0.4	Battitoio per spiantaggio	APPROVED	EXPER. 2312	SIZE A4
		guida valvole	DATE 10/12/2001	SHEET	
			SUPERSEDES		
		MOTORI FIA - FIC	SCALE 1:1	IVECO	
			Q.TY 1		

